

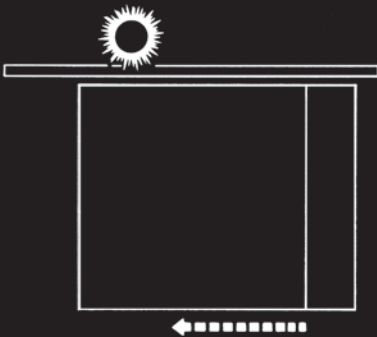

C R O W N
I N D U S T R I A L
O P E R A T O R S

Read
This
FIRST



**GENERAL
INSTALLATION,
OPERATION,
MAINTENANCE,
and PARTS MANUAL
for your**

Aut-o-door

**1265 and 1266
SLIDE DOOR
OPERATORS Model DC-EC**

Copyright © Crown Industrial Operators 2011

Crown Industrial Operators
(Formerly manufactured by Richards-Wilcox)
213 Michelle Court
So. San Francisco, CA 94080
Phone (650) 952-5150
Fax (650) 873-1495
website: www.crown-industrial.com

G-996-DCEC

CONTENTS

PARAGRAPH		PAGE
1	INTRODUCTION	1
	A Purpose	1
	B Models Covered	1
	C Application	1
	D Description	1
2	INSTALLATION AND OPERATION	1
	A General	1
	B Installation of Door Bracket	2
	C Installation of Operator and Support Bracket	2
	D Installation of Idler and Support Bracket	2
	E Installation of Sag Roller	3
	F Alignment of Operator, Sag Roller and Idler Take-Up	3
	G Installation of Chain for Single Slide Doors	3 & 8
	H Installation of Chain for Bi-Parting Doors	8
	I Wiring Operator	8
	J Motor Rotation	8
	K Preliminary Rotary Limit Switch Adjustment	8, 9, 10
	L Vent Plug	10
	M Setting the Clutch	10
	N Setting Run Speed and Creep Speed	10
	O DC Drive Settings	11
	P Final Rotary Limit Switch Adjustment	12
	Q Final Adjustments and Checks	12
3	MAINTENANCE	12
	A General	12
	B Lubrication	12
	C Preventative maintenance	12
4	PARTS	13
	A To Order Replacement Parts	13
	B Parts List	16 & 17
	WARRANTY	18

Note: We reserve the right to modify or change, without prior notice, any statements or information contained herein. If exact dimensions or specifications are required by the customer certified prints will be furnished without charge upon request to Crown Industrial. This manual covers standard catalogued operators only and does not cover special non-standard equipment.

1. GENERAL INTRODUCTION

A. PURPOSE: This Crown Installation, Operation, Maintenance and Parts Manual has been developed to assist you in the installation, operation and maintenance of your electric operator and thus enable you to utilize it to its maximum efficiency.

B. MODELS COVERED: The manual covers current models 1265DC-EC & 1266DC-EC Operators in production and contains the latest information available. Model 1265DC-EC & 1266DC-EC Operators are identical in construction. The Model 1265DC-EC is used specifically for powering single slide doors whereas the Model 1266DC-EC is used specifically for powering bi-parting doors. The parts pages have been prepared so that you can easily determine the parts contained in your operator.

C. APPLICATION: The Model 1265DC-EC & 1266DC-EC electric door operators are not intended for use on openings less than 7'-0" in height unless they have been provided with weather covers. This model of operator offers security as well as quiet, smooth, and precise movement of the door(s). The ramp-up and ramp-down speed functionality helps to control the overall speed of the door in the final seconds of the opening and closing cycles. Furthermore, in the event of power failure, the electric clutch shall disconnect the doors from the drive train, allowing the doors to be operated manually. To prevent manual operation during power failure, a magnetic lock with a battery backup can be added to the system.

D. DESCRIPTION:

The model 1265DC-EC operator consists of a permanent magnet DC motor, a right angle gear reducer, an adjustable electric clutch, and a fully automatic rotary limit switch all assembled into a complete power drive unit assembly. Also included as part of the operator is an adjustable speed DC speed controller, a chain release door bracket, roller chain and an adjustable idler take up assembly. Sag rollers are also furnished for installations 14'-0" wide and over. The model 1265DC-EC electric slide door operator controller converts single phase AC line power to regulated DC for adjustable speed control of a permanent magnet DC motor. The operator run speed and creep speed at the ends of the strokes are field adjustable as well as its acceleration and deceleration. By controlling the starting and stopping torque, this drastically improves the operator and hardware durability and dependability.

Features:

- (a) Adjustable operating speed: 45 ft./min. or 60 ft./min. (Dependent on Application and Opening Width).
- (b) Adjustable creep speed.
- (c) Adjustable Acceleration.
- (d) Adjustable Deceleration.
- (e) Electric Clutch.

2. INSTALLATION AND OPERATION

A. GENERAL

The Crown 1265DC-EC & 1266DC-EC Electric Door Operator has been designed primarily for commercial and industrial installations where the operator has to withstand constant hard use. To ensure correct installation and proper operation of the operator and associated hardware, the following instructions are given:

(1) **SHIPMENT CHECK:** To insure that all equipment is complete, check the components received with the material specifications sheets included with the installation packet supplied with the door.

(2) **CHECK THE DOORS:** After installation of door and track and before starting operator installation, inspect to ensure that the door is in good working condition, is rigidly supported and has no obstruction to block or retard its slide.

(3) **REVIEW THE INSTALLATION DRAWINGS:** The installation drawings show the layout of the door or doors, template drilling for the door and wall, and general terms used to describe components. Review of the drawings will familiarize you with the equipment. To determine the hand of a of single slide doors for operator mounting purposes, stand on the door side of the wall facing through the door opening. If the door slides to your right, it is a right-hand slide door, if it slides to the left, it is a left hand slide door (Figure 2). Mount equipment accordingly.

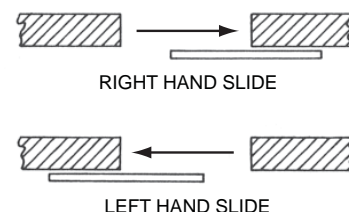

Figure 2. Single Slide Door

B. INSTALLATION OF DOOR BRACKET

(1) In most cases the location of the door bracket from the leading edge of the door is not specified. This permits the positioning of the door bracket to either side of any obstruction near the leading edge of the door, however, it should be located as close to the leading edge of the door as possible.

(2) Locate the door bracket from the leading edge of the door as required and at the same time locate it vertically from the top of the door as shown in Figure 3,4,5,6 or on the drawing for your particular installation. Mount bracket(s) to door using (4) 3/8" dia. fasteners.

C. INSTALLATION OF OPERATOR AND SUPPORT BRACKET

(1) Locate the operator support bracket horizontally from the trailing edge of the door in the closed position. This is done by taking the "A" dimension and adding a minimum of 6" to it with all operators without weather resistant covers and a minimum of 12" to it for all operators with weather resistant covers. The "A" dimension is found by measuring the distance from the leading edge of the door to the center line of the closest mounting bolt on the door bracket. See Figure 3, 4, 5, 6 or the drawing for your particular installation.

(2) The elevation of the operator support bracket also varies but can be found on Figure 3, 4, 5, 6 or on the installation drawing for your particular installation. When

necessary for high track installations, the operator support bracket can be inverted as shown in Figure 7 or 8. Check your track installation for clearance (8-1/2" max. from top of door to top of track standard installation).

(3) Prepare wall for 5/8" dia. fasteners to receive operator support bracket. Mount bracket to wall.

(4) Raise operator into position over support bracket and loosely bolt into place with bolts provided. If operator has a weather resistant cover, remove cover before mounting operator.

D. INSTALLATION OF IDLER AND SUPPORT BRACKET

(1) For 1265DC-EC installations (single sliding doors) locate the idler support bracket no closer than 6" horizontally from the leading edge of the door in the closed position.

(2) For 1266 installations (bi-parting doors) locate the idler support bracket no closer than 6" plus the "A" dimension as described in step C1.

(3) The elevation of the idler support bracket from the top of the door can be found on Figure 3, 4, 5 or 6 or on the installation drawing for your particular installation.

(4) Prepare the wall for 5/8" dia. fasteners to receive the idler support bracket and then secure in place.

(5) Raise the idler housing assembly in place under the support bracket and loosely bolt in place.

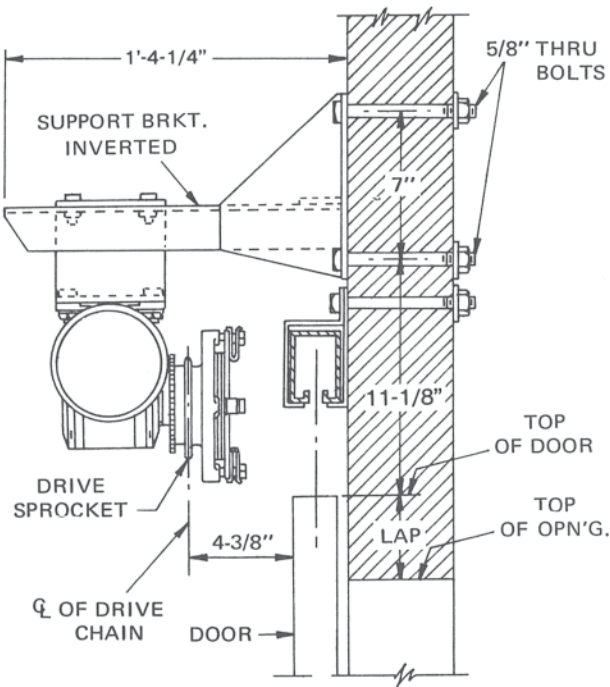

Figure 7. Operator with Bracket Inverted

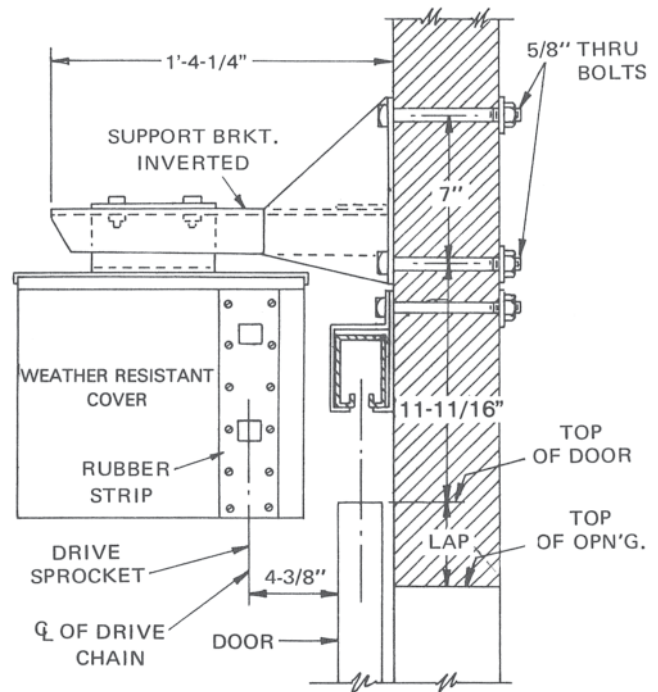

Figure 8. Weather Resistant Covered Operator with Bracket Inverted

E. INSTALLATION OF SAG ROLLER

(1) Sag rollers are furnished for openings 14' wide and over and should be centered above the opening at an elevation as shown on Figure 3, 4, 5, 6 or on the drawing for your particular installation.

(2) Prepare the wall for 5/8" dia. fasteners and mount sag roller in place.

F. OPERATOR, SAG ROLLER AND IDLER TAKE-UP ALIGNMENT

(1) Note that the dimension from face the door to the center of chain latch on the door bracket is 4-3/8". (Figure 3, 4, 5, 6 or drawing for your particular installation)

(2) Slide the operator either outward or toward the wall until the 4-3/8" dimension is obtained between the face of the door and center line of the drive sprocket. With operator parallel to door, secure in place.

(3) Loosen sag roller support connection and slide in or out to obtain the 4-3/8" dimension between face of the door and the roller(s) center line. Secure in place.

(4) Slide idler housing assembly outward or toward the wall to obtain the 4-3/8" dimension between the face of the door and the center line of the drive sprocket. With operator parallel to door, secure in place. At this point, check the chain latch(s) and sag roller(s) for vertical adjustment. For single slide installations, stand at the end of the operator and sight along the bottom of the drive sprocket teeth across to the bottom of teeth of the idler take-up sprocket. Between them at the same level should be the opening in the chain latch; if it is not, raise or lower the latch accordingly. The elevation of the sag roller can be checked by sighting along the top of the drive sprocket teeth across to the top of the teeth of the idler take-up sprocket. The center flat section on the sag roller should be directly under this sighted elevation, adjust accordingly. For bi-parting installations, there is a chain latch and a sag roller to site for along both the top of the sprockets and along the bottom of the sprockets. Adjust accordingly.

G. INSTALLATION OF CHAIN FOR SINGLE SLIDE DOORS

(1) 1265DC-EC operators are furnished with one run of roller chain with a long link in the center and several connecting links. Install in the sequence given in the following paragraphs.

(2) Pull down on the manual release chain on door bracket and hold. Insert chain through chain latch until the long link falls over center of latch. Release hold on

manual release chain. (See Figure 9)

(3a) For 1265DC-EC operators without weather resistant covers, bring one end of the roller chain around bottom of drive sprocket on operator and back over the sag roller. (See Figure 3). Loosen idler take-up and allow it to slide inward toward the opening. Bring the other end of the roller chain around bottom of idler sprocket and back towards the other end of the chain. Pull roller chain tight by hand, match ends and cut to length. Connect ends with roller chain connecting link.

(3b) For 1265DC-EC operators with weather resistant covers, remove the rubber slotted strip from the lower portion of the weather resistant cover. Bring one end of the roller chain through the lower hole in the rubber strip, around under the drive sprocket on the operator, through the top hole in the rubber strip and back over the sag roller. (See Figure 5 or 8). Loosen the idler take-up and allow it to slide inward toward the opening. Bring the other end of the roller chain around bottom of the idler sprocket and back towards the other end of the chain. Pull roller chain tight by hand, match ends and cut to length. Connect ends with roller chain connecting links. Cover will be reassembled later.

(3c) Another method for handling weather resistant covers is to follow step 3a and then slit the rubber strip in the lower portion of the cover down to the bottom hole for installation later.

(4) Apply medium tension to roller chain by turning take-up nut located on the end of the idler housing.

CAUTION: EXCESSIVE CHAIN TIGHTNESS COULD CAUSE EXTREME WEAR ON THE IDLER SPROCKET AND SHORT LIFE. CONVERSELY, A LOOSE CHAIN COULD JUMP THE DRIVE SPROCKET AND JAMB OR CHANGE DOOR STOPPING POINTS.

Upon reaching the proper chain tension, lock nut on inside of idler housing against rear of housing. Also lock the bolt which runs through the idler sprocket.

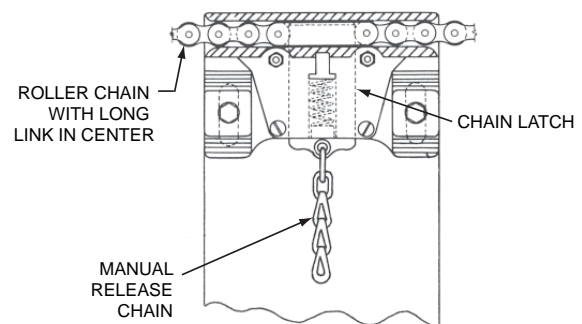
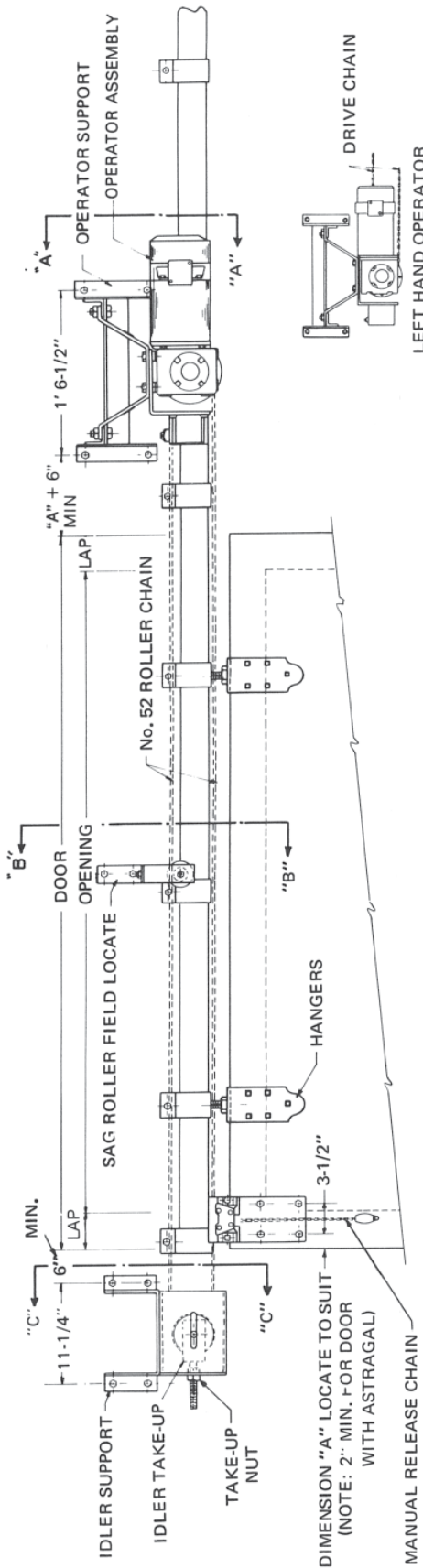
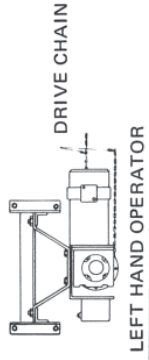

Figure 9. Door Bracket



ELEVATION OF No. 1265 ELECTRIC OPERATOR

- NOTE: 1. RIGHT HAND ELEVATION SHOWN.
2. LEFT HAND ELEVATION OPPOSITE EXCEPT AS NOTED.
3. SAG ROLLERS ARE FURNISHED FOR OPENINGS 14'-0" AND OVER.



NOTE: OPERATOR IS THE SAME HAND AS FOR RIGHT HAND OPERATORS

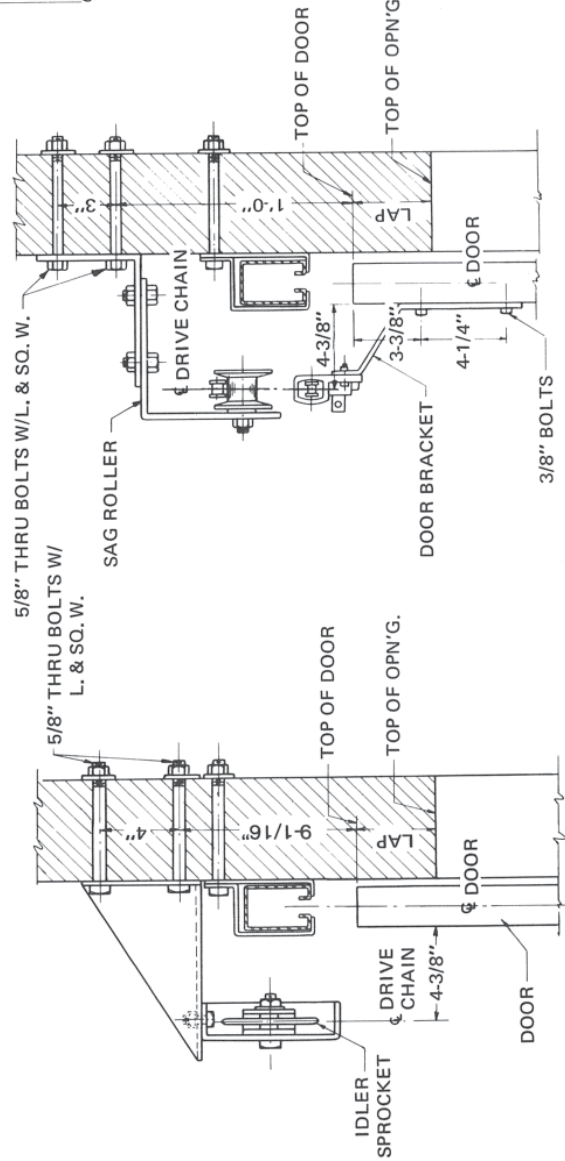

SECTION "A-A" AT OPERATOR
ALSO SEE FIG. 7, PAGE 6.

SECTION "B-B" AT SAG ROLLER & DOOR BRACKET

SECTION "C-C" AT IDLER

Figure 3. Installation of 1265 Operator

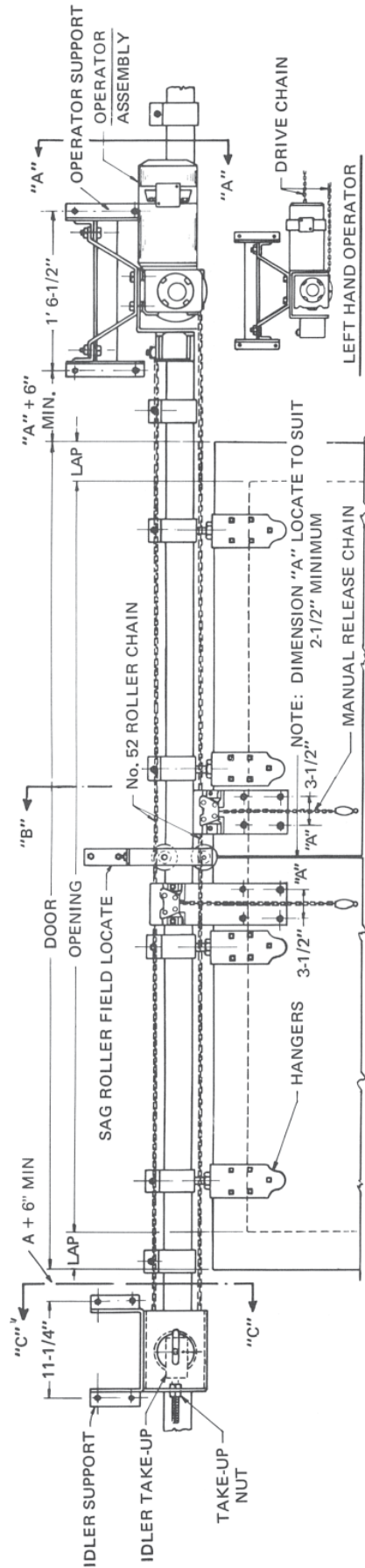

ELEVATION OF No. 1266 ELECTRIC OPERATOR

NOTE: OPERATOR IS THE SAME HAND AS FOR RIGHT HAND OPERATORS

NOTE: DIMENSION "A" LOCATE TO SUIT 2-1/2" MINIMUM

ELEVATION OF No. 1266 ELECTRIC OPERATOR

NOTE: 1. RIGHT HAND ELEVATION SHOWN
 2. LEFT HAND ELEVATION OPPOSITE EXCEPT AS NOTED
 3. SAG ROLLERS ARE FURNISHED FOR OPENINGS 14'-0" AND OVER

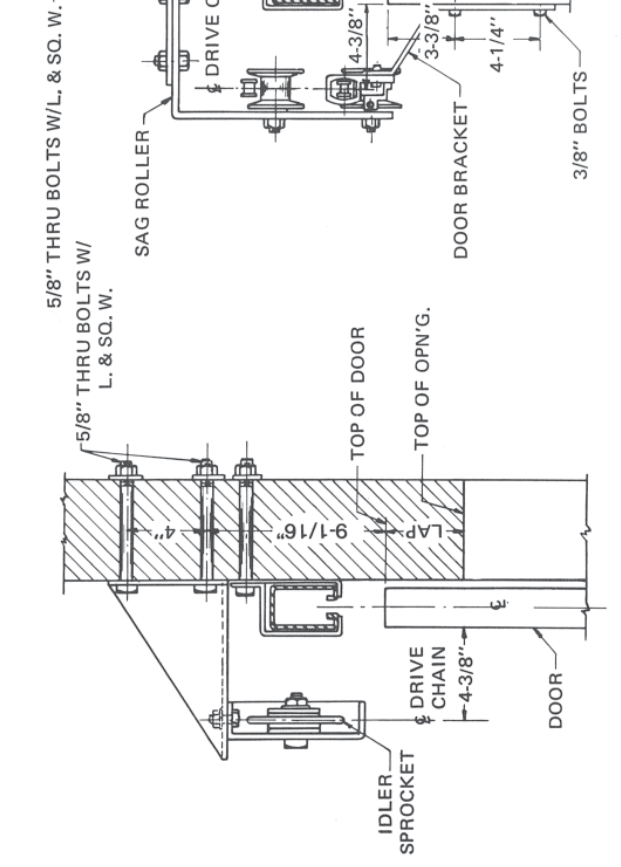

SECTION "C-C" AT IDLER

SECTION "B-B" AT SAG ROLLER & DOOR BRACKET

SECTION "A-A" AT OPERATOR

ALSO SEE FIG. 7, PAGE 6.

Figure 4. Installation of 1266 Operator

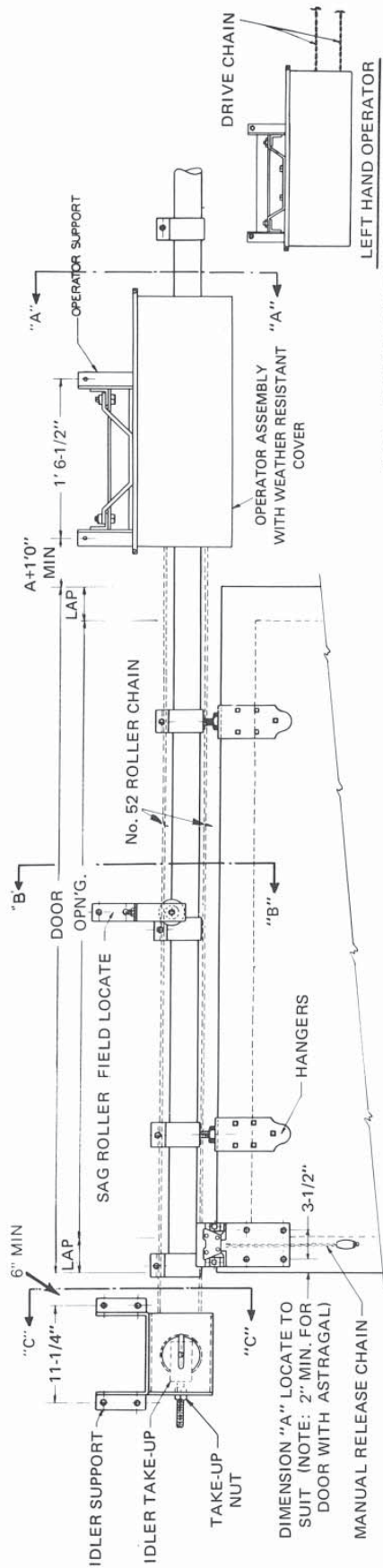

ELEVATION OF No. 1265 ELECTRIC OPERATOR
WITH WEATHER RESISTANT COVER

- NOTE: 1. RIGHT HAND ELEVATION SHOWN.
2. LEFT HAND ELEVATION OPPOSITE EXCEPT AS NOTED.
3. SAG ROLLERS ARE FURNISHED FOR OPENINGS 14'-0" AND OVER

LEFT HAND OPERATOR
NOTE: OPERATOR IS THE SAME HAND AS FOR RIGHT HAND OPERATORS

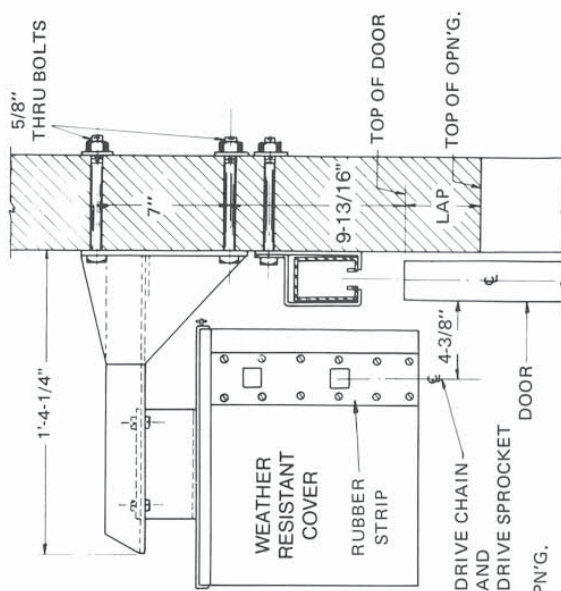

SECTION "A-A" AT OPERATOR
ALSO SEE FIG. 8, PAGE 6.

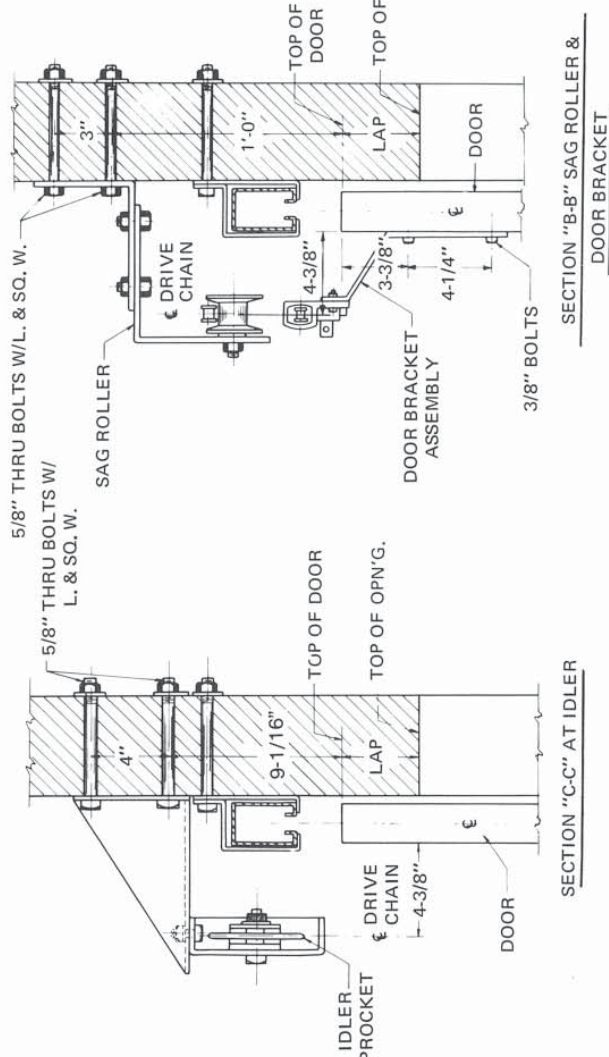

SECTION "B-B" SAG ROLLER &
DOOR BRACKET ASSEMBLY

SECTION "C-C" AT IDLER

Figure 5. Installation of 1265 Operator with Weather Resistant Cover

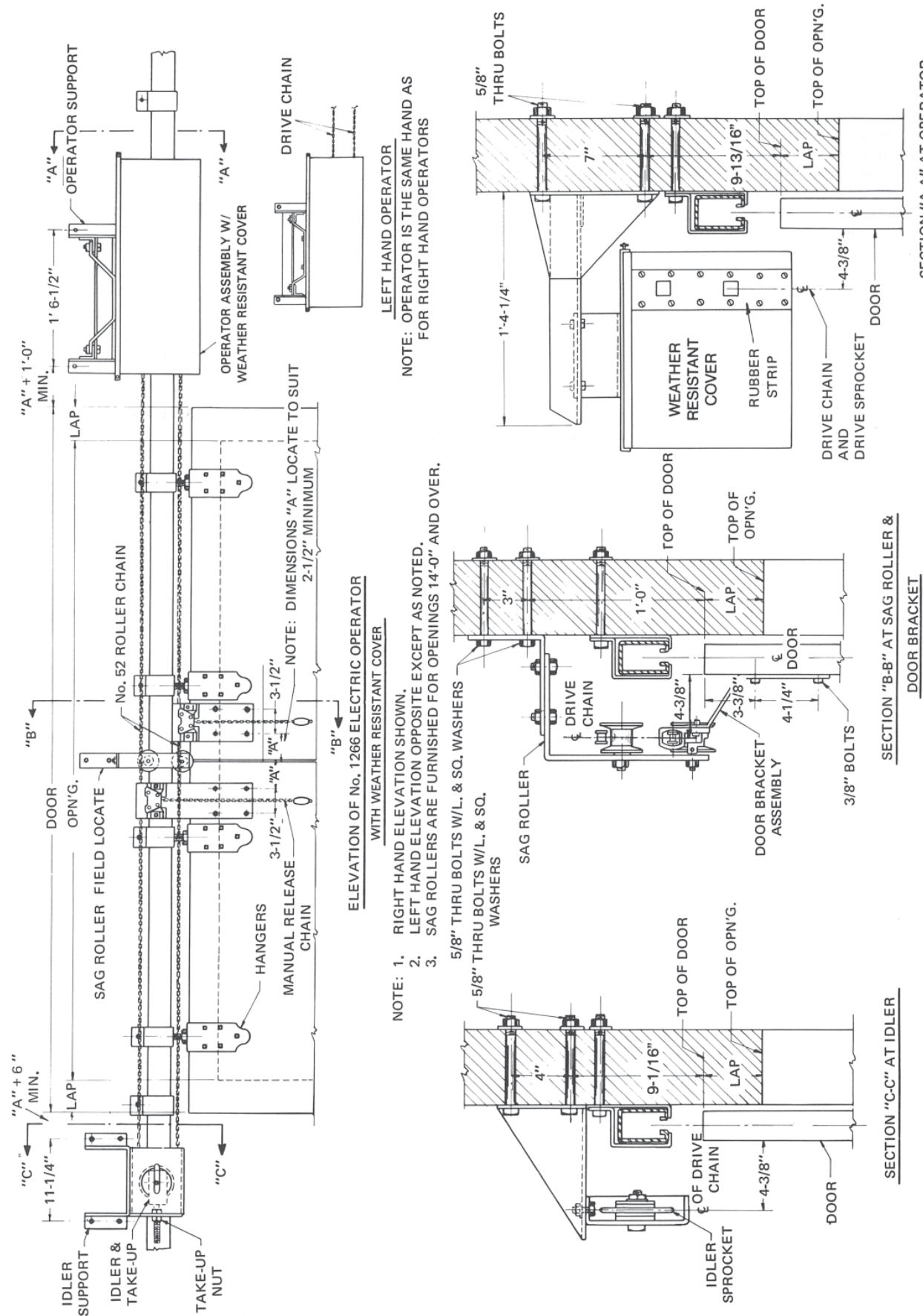

LEFT HAND OPERATOR
NOTE: OPERATOR IS THE SAME HAND AS
FOR RIGHT HAND OPERATORS

ELEVATION OF No. 1266 ELECTRIC OPERATOR
WITH WEATHER RESISTANT COVER
NOTE: 1. RIGHT HAND ELEVATION SHOWN.
2. LEFT HAND ELEVATION OPPOSITE EXCEPT AS NOTED.
3. SAG ROLLERS ARE FURNISHED FOR OPENINGS 14'-0" AND OVER.

SECTION "A-A" AT OPERATOR
ALSO SEE FIG. 8, PAGE 6.

SECTION "B-B" AT SAG ROLLER &
DOOR BRACKET

SECTION "C-C" AT IDLER

Figure 6. Installation of 1266 Operator With Weather Resistant Cover

(5) At this point, check all components - operator, door bracket, sag roller and idler - for proper alignment.

NOTE: It is required that the chain latch, idler sprocket, and clutch drive sprocket be properly aligned for smooth operation of the door and for long life of operator parts.

H. INSTALLATION OF CHAIN FOR BI-PARTING DOORS

(1) The installation procedures for bi-parting doors is the same as that for the single sliding doors with the following exceptions:

(a) The doors must be in the fully closed position during the entire chain installation process.

(b) There are two runs of roller chains furnished, each with a long link in the center of the chain latch on the door brackets. (See Figure 9).

(c) Center each long link in each chain latch. Bring the roller chain from the same side of each bracket around idler sprocket, pull tight by hand, match ends and cut to length. The chain from the other side of the brackets are pulled tight around the drive sprocket on the operator and with the end matched, cut to length. Connect ends with roller chain connecting links. (See Figure 4 or 6).

I. WIRING OPERATOR

(1) 1265DC-EC and 1266DC-EC electric door operators are intended application to motor branch circuits with voltage and current characteristics to meet operator ratings. Branch circuit, branch circuit disconnecting means and branch circuit overcurrent protection are to be properly sized in respect to the operator horsepower rating.

(2) Wire operator power and controls as shown on the wiring diagram provided in the operator packing list envelope.

WARNING: Ensure operator branch circuit is disconnected from power source when installing, adjusting, or servicing operator.

(3) Wire operator and control circuit as shown on the wiring diagram in the packing list envelope. Be sure all power is off.

J. MOTOR ROTATION

(1) Loosen all four bolts on operator friction clutch so that drive sprocket is free to rotate with roller chain, when gearmotor is not running. (See Figure 12)

(2) Determine if the system controls are set up as Momentary or Constant pressure.

Constant Pressure: Each time the actuator is depressed the operator is energized. The operator will run only when the actuator is held in the depressed position.

Momentary: When the actuator is depressed the operator shall start up and continue to operate until the appropriate limit switch is activated or a STOP button is depressed.

IF MOMENTARY CONTROLS ARE USED CONSULT FACTORY BEFORE PROCEEDING.

Step 1:

With clutch bolts loosened and the door free to move by hand, turn the power ON. Depress "Open" push button. Does the Relay in the control box labeled "O" light? If YES, proceed to step (2), if NO, TURN POWER OFF and check the wiring from the "OPEN" activation switch to the control box.

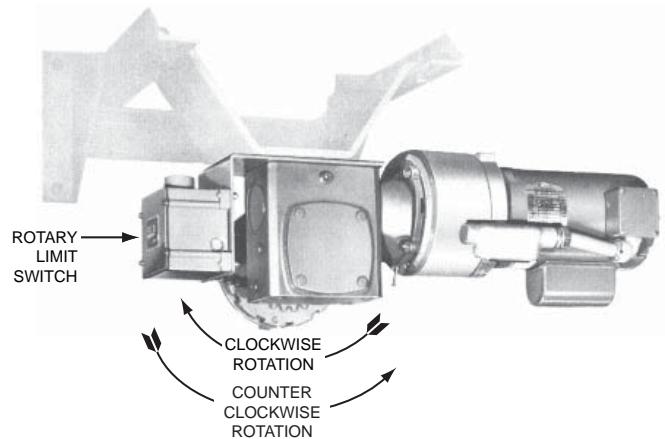

Figure 10.

Step 2:

Is the operator rotating the proper direction to open the door? If NO, turn off power to the operator control box. Switch the motor wires typically labeled M1 & M2 or A1 & A2, located at the bottom of the control box. Turn the power back on and check for proper rotation (See Figure 10).

K. PRELIMINARY ROTARY LIMIT SWITCH ADJUSTMENT

(1) DESCRIPTION: The rotary limit switch is designed to accurately control the end limits of the door travel provided by the electric operator as well as the activation point and duration of the creep mode. The limit switch input shaft drives a set of planetary gears which in turn drives a set of nylon cams (See Figure 11). Each precision limit switch unit is actuated by its individual nylon cam. The cam rotate as the operator travels the door back and forth. The cam contact the electrical snap switches to either stop the travel of the operator or initiate the creep modes. The limit switch has 4 switches.

- (a) LSO = Limit Switch Open
This limit shuts off the electric operator when the door reaches the full open position.
- (b) LSC = Limit Switch Close
This limit shuts off the operator when the door has reaches the full closed position.
- (c) LSCO = Limit Switch Creep Open
This limit activates the creep mode during the end of open cycle. When the limit switch is actuated the door travels in the open direction at a reduced speed.
- (d) LSCC = Limit Switch Creep Close
This limit activates the creep mode during the closing cycle. When this limit switch is actuated the door travels in the closed direction at a reduced speed.

To adjust each individual limit switch, turn the screw adjustment for each specific limit switch. Note that depending upon the handing of the operator the cams

travel from either the clockwise or counterclockwise direction to activate the appropriate snap switches.

(2) PREPARATION FOR ADJUSTMENT:

- (a) **Disconnect the Electrical Power Supply to the Operator Control Box.**
- (b) Unscrew limit switch cover and expose assembly.

(3) ROUGH ADJUSTMENT:

- (a) Manually slide the door in the open direction and note the direction the LSO cam lobe is traveling. Clockwise or counterclockwise?
- (b) Manually slide the door to approximately 6" from the full open position.
- (c) Adjust the LSO cam adjuster until the cam contacts the electrical snap switch from the same direction and you hear it click.
- (d) Manually slide the door towards the closed direction and back towards the open direction. The snap switch should click when the door gets approx. 6" from the full open position.

Rotary Cam Limit Switch Assembly

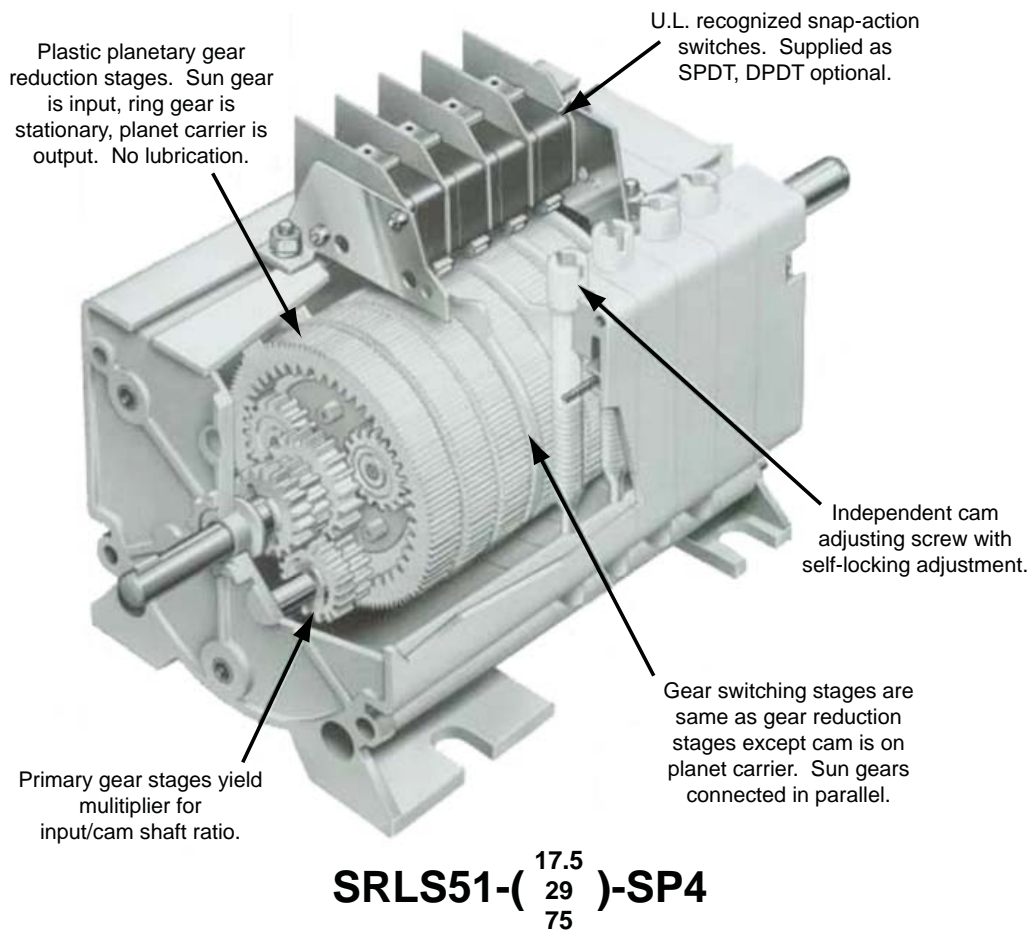

Figure 11.

- (e) Position the door approx. 12" from the full open position.
- (f) Turn the LSCO cam adjusting screw until the cam contacts the electrical snap switch from the same direction as the LSO switch and you hear it click.
Note: This cam is longer and the operator shall only travel in closed creep mode while this cam is depressing the snap switch.
- (g) Repeat Step (d). The LSCO the snap switch should click when the door gets approx. 12" from the full open position.
- (h) Manually slide the door to approximately 6" from the full closed position.
- (i) Turn the LSC cam adjusting screw until the cam contacts the electrical snap switch from the opposite direction and you hear it click.
- (j) Manually slide the door towards the open direction and back towards the closed direction. The snap switch should click when the door gets approx. 6" from the full closed position.
- (k) Position the door approx. 12" from the fully closed position.
- (l) Turn the LSCO cam adjusting screw until the cam contacts the electrical snap switch from the same direction as the LSC switch and you hear it click.
Note: This cam is longer and the operator shall only travel in open creep mode while the cam is depressing the snap switch.
- (m) Repeat step (j) LSCO the snap switch should click when the door gets approx. 12" from the full open position.
- (n) Move the door back and forth noting that the proper snap switches are being contacted from the proper direction at the proper time.

L. VENT PLUG

Remove the 1/2" NPT steel pipe plug located nearest the top of the gearbox and replace it with the plastic vent plug provided with the operator (See Figure 16).

M. SETTING THE CLUTCH

(1) The purpose of the clutch is to protect the equipment from shock loads that might be introduced into the system. Under normal operation the clutch will not slip. Therefore, the clutch should be adjusted to a sufficient torque that will allow the operator to start and stop the door without any slipping. Keep in mind also that the clutch should not be so tight that it cannot slip under excessive loads.

(2) The magnetic clutch has an adjustable torque output feature. The output is controlled by rotating the electronic clutch controller located in the main control panel. When the voltage is reduced the clutch torque characteristics are de-rated. The clutch should be set with just enough power to move the door. Turning off the power to the operator will power off the clutch controller

and will allow the door to be operated manually. As an additional option, a magnetic lock with battery backup can be used to prevent manual operation of the door during power failure.

N. SETTING RUN SPEED AND CREEP SPEED

Inside the operator control box locate the run speed and creep speed potentiometers (Figure 13). The potentiometers control the run and creep speeds of the operator. Turning them clockwise increases the rate of travel.

- (a) Carefully turn the run speed potentiometer all the way counterclockwise and then back clockwise approx. 135 degrees.
- (b) Carefully turn the creep speed potentiometer all the way counterclockwise and then back clockwise approx. 20 degrees.
- (c) Release the drive chain latch and affix it so that it cannot reattach automatically. Note the location of the long link, this is where the chain latch attaches to the drive chain.
- (d) Turn ON the power to the operator controller.
- (e) Actuate a push button to run the operator. The operator should travel the door in the appropriate direction, slow down and creep into approximately the full open or closed position.
- (f) Reconnect chain latch to long link. Operate the door open and closed.
- (g) To increase or decrease the travel speed in both run and creep speed adjust the appropriate potentiometer clockwise to increase the speed and counterclockwise to decrease the speed.
- (h) Set the run and creep speeds to the desired levels.

O. DC DRIVE SETTINGS

(1) ACCEL/DECEL

The DC drive located inside the operator control box has separate potentiometers for both ACCEL and DECEL. These are typically set at the factory but are field adjustable. Depending upon the size and weight of a specific door, it may be necessary to field adjust the

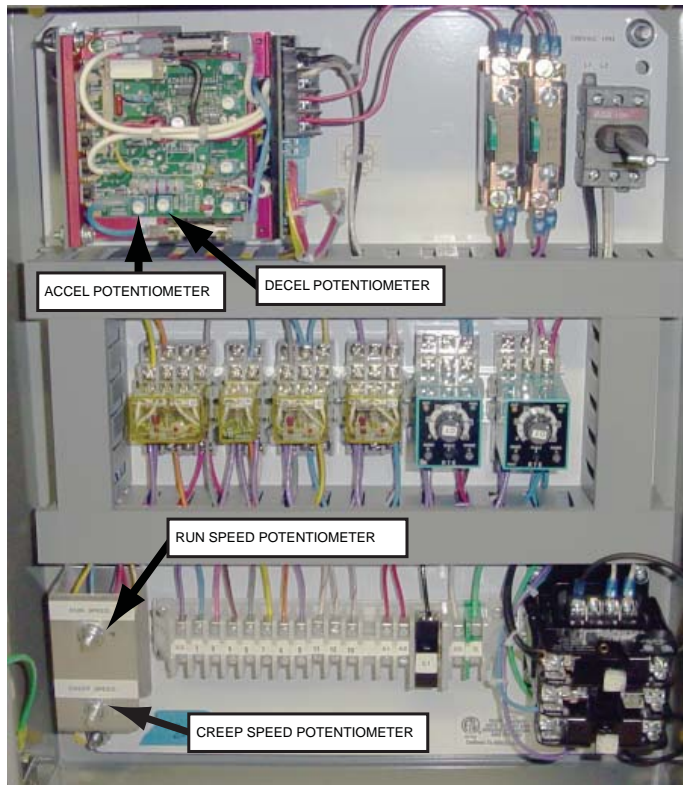

Figure 13.

ACCEL & DECEL to allow for the operator to smoothly ramp up to full run speed and smoothly ramp down to creep speed (See Figure 13, 14 & 15).

The ACCEL potentiometer controls the acceleration from 0 to the run speed setting. **The minimum ACCEL setting should be 1 second.**

The following procedure, presented in order of adjustment sequence, should be used when re-adjusting all trimpot functions:

CAUTION!

[PM motors only]. Adjusting the accel time below .5 seconds increases inrush current. It may be necessary to measure the peak inrush current and consult with motor manufacturer since field magnet demagnetization may occur.

FACTORY SETTING 1 SEC.

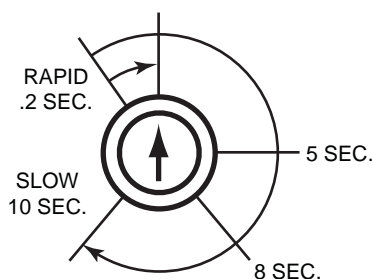

ACCEL

FACTORY SETTING 1 SEC.

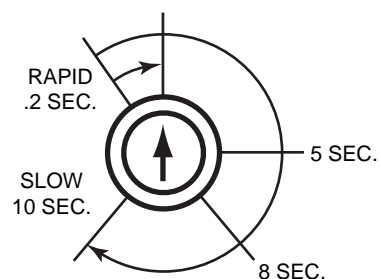

DECEL

Figure 15.

The DECEL potentiometer controls the deceleration rate from run speed to creep speed.

To adjust either the ACCEL or DECEL, turn the potentiometer clockwise to increase the duration of time to accelerate or decelerate, and counterclockwise to decrease the time. The setting must take into account the run speed, weight of the door and the length of the creep mode. The faster the travel and/or the heavier the door the longer the transition time should be.

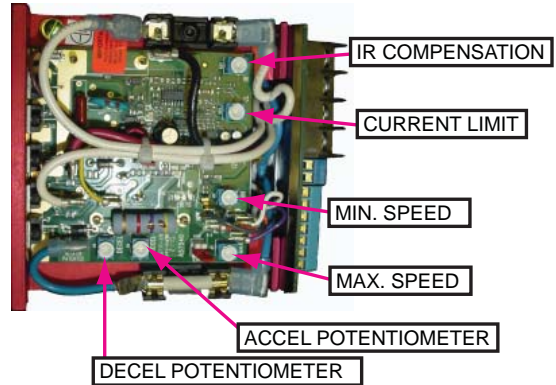

Figure 14.

DO NOT ATTEMPT TO ADJUST THE OTHER POTENTIOMETERS ON THE DC CONTROL BOARD. THEY ARE FACTORY SET & ADJUSTMENTS WILL DAMAGE THE UNIT AND VOID THE WARRANTY.

(2) MAXIMUM SPEED - factory set, do not adjust without consulting factory

(3) MINIMUM SPEED - factory set, do not adjust without consulting factory

(4) CURRENT LIMIT - factory set, do not adjust without consulting factory

(5) IR COMPENSATION - factory set, do not adjust without consulting factory

P. FINAL ROTARY LIMIT SWITCH ADJUSTMENT

After the run speed, creep speed and ACCEL & DECEL have been adjusted, the final limit switch settings can be made.

- (a) Actuate the operator controls and adjust the rotary limit switches (LSO & LSC) to stop the door in the full open and closed positions.
- (b) Actuate the operator and adjust the rotary limit switches (LSCO & LSCC) to initiate the creep mode at the desired time. Keep in mind that the operator only travels in creep mode as long as the cam lobe is depressing the snap switch.

Note: The length of time the operator is running in creep mode must be long enough to allow for it to dynamically brake from run speed to creep speed plus the desired length of time the operator is traveling under creep mode. If the DECEL time is set for too long, the creep mode may be adversely affected.

- (c) After adjusting LSCO & LSCC check the travel of the door. LSC & LSO may need to be re-adjusted.
- (d) Activate the operator to open and close the door several times and fine tune the limit switch

settings.

- (e) Close limit switch cover and tighten down screw clamp.
- (f) Periodically the limit switches may require adjustment. This is especially evident during the initial few weeks after start up due to chain stretch and wear in.

Q. FINAL ADJUSTMENTS & CHECKS

(1) Make final check of operator, door bracket(s), sag roller(s) and idler take-up alignment. It is extremely important that the operator be run several times to check chain alignment. Make corrections as needed.

Note: It is required that the chain latch, idler sprocket, and clutch drive sprocket be properly aligned for smooth operation of the operator for long life of drive components.

(2) For 1265 & 1266 operators with weather resistant covers, slip lower portion of cover into position up over operator and secure.

3. MAINTENANCE

A. GENERAL

To insure that the electric operator is ready for operation at all times, it must be inspected systematically which will preclude serious damage or failure. Proper adjustment and lubrication must be maintained and checked as recommended below.

B. LUBRICATION

(1) LUBRICATION FOR GEARMOTOR

(a) Figure 16 shows the proper location of vent, oil level, and drain plugs.

(b) The drive unit is pre-lubricated and shipped with Mobil "SHC 634" synthetic lubricant. This oil is a lifetime lubricant rated for operation in ambient temperatures ranging from -40°F to +125°F.

(2) Every 900 cycles, where one cycle consists of opening and closing of the door, or every 3 months whichever comes first, clean and lubricate the chain with a SAE lubricant as required for ambient temperature.

C. PREVENTIVE MAINTENANCE

To prevent damage or improper operation, the following inspections should be let made at least EVERY 6 MONTHS.

- (1) Check oil level by removing the oil level plug. Oil should be up to the bottom of the plug hole.
- (2) Check tension of chain.
- (3) Check all electrical components and wiring for tightness.
- (4) Check clutch to see that it doesn't slip under normal operation.
- (5) Check all bolts and nuts for tightness.

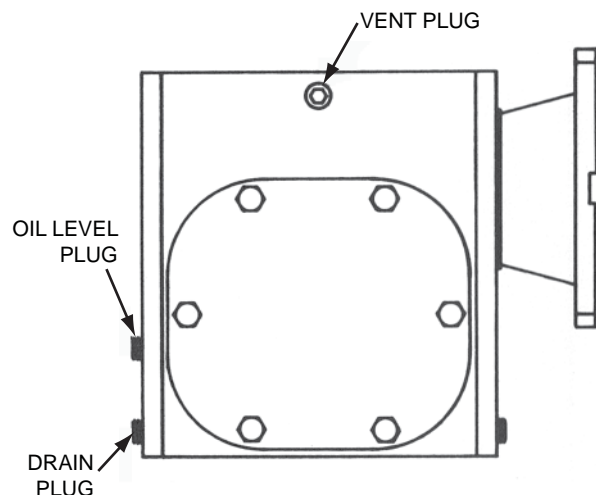

Figure 16.

4. PARTS

A. TO ORDER REPLACEMENT PARTS

Order all replacement parts using the number shown on the following parts list pages.

- (1) SEND IN SERIAL NUMBER OF ELECTRIC OPERATOR.
- (2) SPECIFY the number of pieces needed.
- (3) Order by part number and name of part.
- (4) State whether to ship by freight, truck, parcel post, or air express.
- (5) State whether transportation charges are to be prepaid or collect.
- (6) Give name and address of the person or company to whom the parts are to be shipped.
- (7) Give name and address of person or company to whom the invoices to be sent.

B. PARTS LIST

The following pages list the replacement parts which are illustrated in Figure 17 and 18.

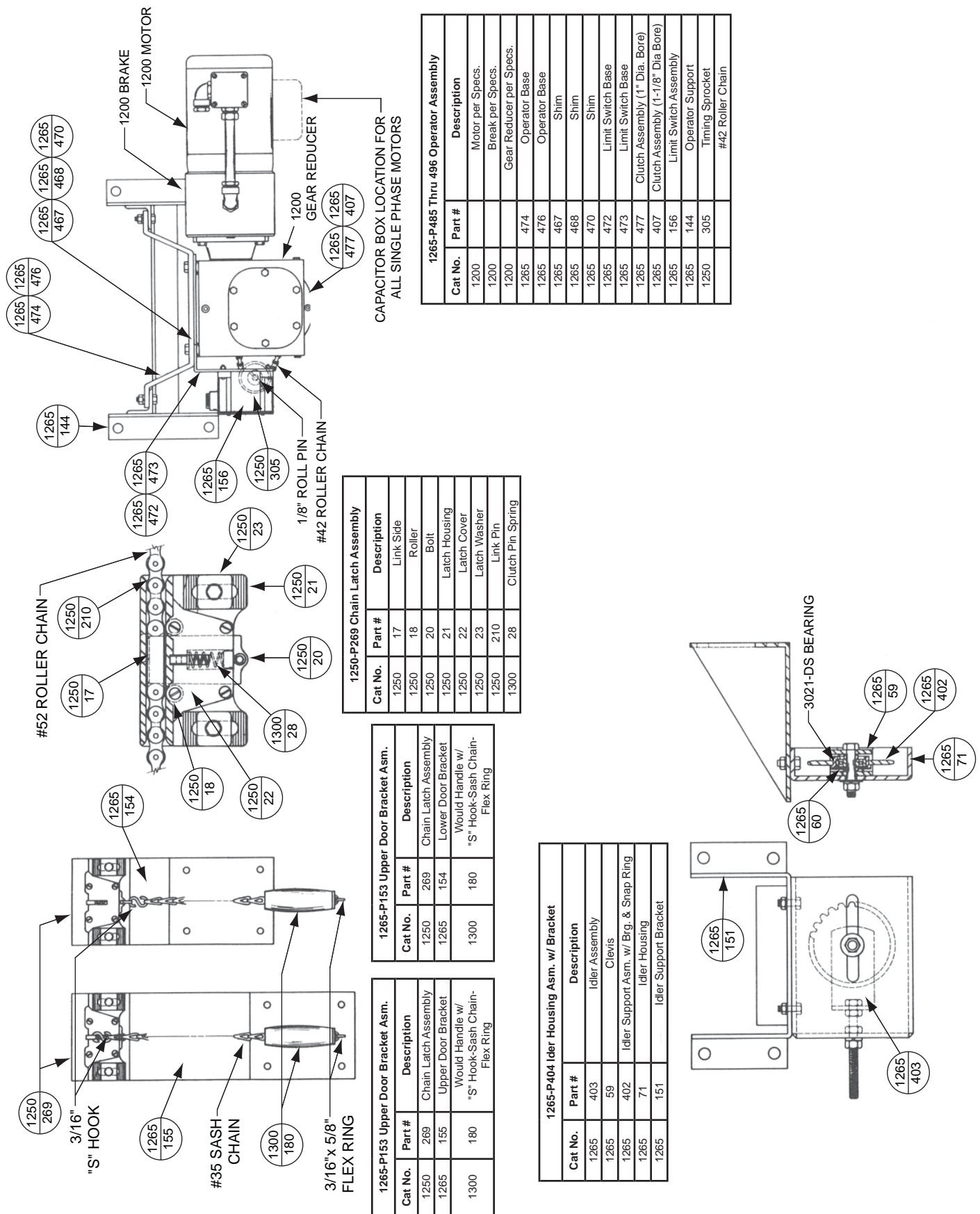
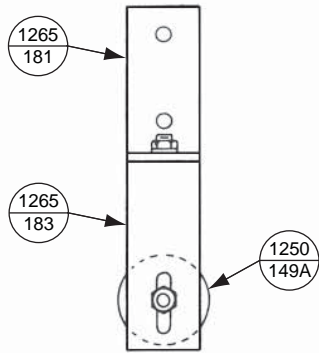

Figure 17. Illustration of Parts-Operator, Idler, Door Brackets & Clutch

Crown Industrial Operators • 213 Michelle Ct. • So. San Francisco, Ca 94080-6202

Phone: (650) 952-5150 • Fax: (650) 873-1495

www.crown-industrial.com Email: autodor@crown-industrial.com



1265-179A SINGLE SAG ROLLER ASSEMBLY		
Cat No.	Part #	Description
1250	149A	Chain Guide Roller Assembly
1265	181	Chain Guide Bracket
1265	182	Single Roller Bracket

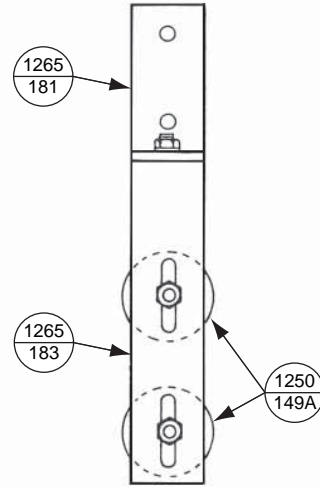

1265-180A DOUBLE SAG ROLLER ASSEMBLY		
Cat No.	Part #	Description
1250	149A	Chain Guide Roller Assembly
1265	181	Chain Guide Bracket
1265	183	Double Roller Bracket

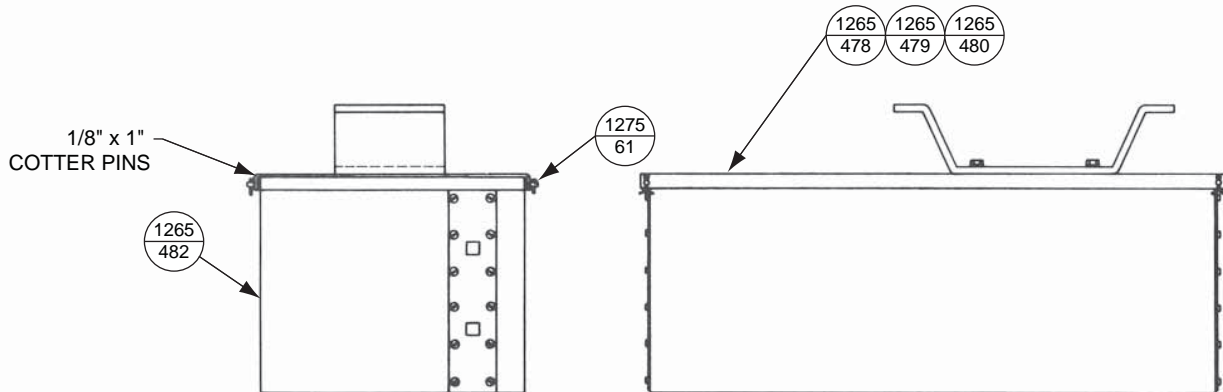

1265 WEATHER-RESISTANT COVER ASSEMBLY		
Cat No.	Part #	Description
1265	478	Cover Base 1/2 H.P. for 60 F.P.M.
1265	479	Cover Base 1/2 H.P. for 45 F.P.M.
1265	480	Cover Base 1 H.P.
1265	482	Weather-Resistant Cover
1275	61	Retaining Rod
		1/8" x 1" Cotter Pins

Figure 18. Illustration of Parts-Weather Resistant Cover and Sag Roller Assembly

PARTS LIST

MODELS 1265 AND 1266 OPERATOR ASSEMBLY

FIGURE NO.	PART NUMBER	DESCRIPTION
19	1200	Motor Per Specifications
19	1200	Gear Reducer Per Specifications
19	1200	Break Per Specifications
19	1250-305	Timing Sprocket
19	1265-144	Operator Support Bracket
19	SRLS51-()-SP4	Limit Switch Assembly (Indicate 17.5, 29 or 75
19	1265-407	Clutch Assembly (1 1/8" Dia. Bore)
19	1265-467	Shim - 1/2 H.P. *
19	1265-468	Shim - 3/4 H.P. *
19	1265-470	Shim - 1/2 & 3/4 H.P. *
19	1265-472	Limit Switch Base - 1/2 H.P.
19	1265-473	Limit Switch Base - 1 H.P.
19	1275-474	Operator Base 1/2 H.P.
19	1265-476	Operator Base 1 H.P.
19		#42 Roller Chain with Connecting Link *4 per assembly with weather resistant cover

1265-152A DOOR BRACKET ASSEMBLY

19	1250-269A	Chain Latch Assembly
19	1265-154	Door Bracket
19	1300-180	Wood Handle
19		#35 Sash Chain With "S" Hook, 266-7 Washer, and 3/16 x 5/8" Flex Ring Per Specifications

1265-153A DOOR BRACKET ASSEMBLY (For Use on 1266 Installations Only)

19	1250-269A	Chain Latch Assembly
19	1265-155	Door Bracket
19	1300-180	Wood Handle
19		#35 Sash Chain With "S" Hook, 266-7 Washer, and 3/16 x 5/8" Flex Ring Per Specifications

PARTS LIST

1250-269A CHAIN LATCH ASSEMBLY

FIGURE NO.	PART NUMBER	DESCRIPTION
19	1250-18	Roller (2 Per Assembly)
19	1250-20	Bolt
19	1250-21	Latch Housing
19	1250-22	Latch Cover
19	1250-23	Latch Washer (2 Per Assembly)
19	1300-28	Spring

IDLER TAKE-UP AND SUPPORT

19	1265-151	Idler Support Bracket
19	1265-404A	Idler Housing Assembly

1265-404A IDLER HOUSING ASSEMBLY

19	1265-59	Clevis
19	1265-60	Spacer (2 Per Assembly)
19	1265-71	Housing
19	1265-402A	Sprocket Assembly
19	3021-DS	Bearing

1265-179A SINGLE SAG ROLLER ASSEMBLY (For 1265 Operator Installation Only)

20	1250-149A	Roller Assembly
20	1265-181	Roller Support Bracket
20	1265-182	Single Roller Bracket

1265-180A DOUBLE SAG ROLLER ASSEMBLY (For 1266 Operator Installation Only)

20	1250-149A	Roller Assembly (2 Per Assembly)
20	1265-181	Roller Support Bracket
20	1265-183	Double Roller Bracket

WEATHER-RESISTANT COVER ASSEMBLY

20	1265-478	Cover Base 1/2 H.P. for 60 F.P.M.
20	1265-479	Cover Base 1/2 for 45 F.P.M.
20	1265-480	Cover Base 1 H.P.
20	1265-482	Weather-Resistant Cover w/ 1275-61 Retaining Rods and 1/8" x 1" Cotter Pins

MAINTENANCE INFORMATION

(To Be Filled Out By User)

Operator Serial Number _____ H.P. _____

Supplied on Crown Industrial Operators Order Number _____

Power Supply _____ Volts _____ Hz _____ Phase _____

Installed At _____ Date _____

Notes _____

GUARANTEE

If, within a period of one year from date of shipment, any part of a CIO Electric "Aut-o-doR" Operator is found defective due to poor materials or workmanship, new parts will be furnished free of charge F.O.B. manufacturer's plant, providing the equipment has been given normal and proper usage, lubrication, and maintenance and is still the property of the original purchaser and/or part of the original installation. *THIS WARRANTY IS GIVEN IN LIEU OF ALL OTHER WARRANTIES, EXPRESSED OR IMPLIED, AND THE MANUFACTURER MAKES NO IMPLIED WARRANTY OF MERCHANTABILITY BEYOND THE EXPRESSED TERMS HEREOF. MANUFACTURER'S LIABILITY FOR DAMAGES, INCLUDING CONSEQUENTIAL DAMAGES RESULTING FROM ANY SUCH DEFECTIVE PRODUCT IS STRICTLY LIMITED TO THE DELIVERY OF NEW PARTS, AS SET FORTH ABOVE.*



Crown Industrial Operators

213 Michelle Court

So. San Francisco, CA 94080

Phone (650) 952-5150

Fax (650) 873-1495

website: www.crown-industrial.com

G-996DCEC